

Rheo-SAS: Small-Angle-Scattering techniques used in combination with Rheology

Jörg Läger

Anton Paar Germany GmbH,
Helmuth-Hirth-Str. 6, D-73760 Ostfildern / Germany
Phone: +49-711-72091-0, Fax:+49-711-72091-50
info.de@anton-paar.com, www.anton-paar.com

ABSTRACT

New devices for a simultaneous measurement of the rheology and the structural information based on Small-Angle-Scattering (SAS) are described. Depending on the exact application Light, x-ray, or neutron scattering is employed. The various experimental setups and typical application examples are discussed.

INTRODUCTION

In order to understand the behaviour of complex fluids under flow it is necessary to pay special attention to structural changes that occur at the micro-structural level. This goal can be achieved by using small angle scattering methods implying neutron, x-ray as well as light radiation. For characterization of materials in the mesoscopic scale techniques like Small Angle x-ray Scattering (SAXS) or Small Angle Neutron Scattering (SANS) are often employed. Suitable for structure investigations in the micrometer-size range simultaneously with rheological measurements is Small Angle Light Scattering (SALS). The principle for all small angle techniques is very similar. An incoming beam is scattered at the sample and the angular distribution of the scattering intensity is analyzed. The scattering gives information on the structural details. The contrast responsible for the scattering is in

case of SALS the polarizability, for SAXS it is the electron density, whereas in SANS the neutrons are scattered at the atomic nuclei. In order to facilitate these structure investigation techniques in combination with quantitative rheological measurements, devices for the various techniques have been designed, which can be adapted directly onto a standard research rheometer. For all systems special emphasis has been put onto an excellent temperature control which avoids any significant temperature gradients in the sample.

RHEO-SALS

SALS have often been used in combination with rheology. The already existing Rheo-SALS setup has now been completely redesigned. The main advantages of the new Rheo-SALS device are the optical quality with a telecentric optics which focuses the scattered light directly onto the CCD chip of the camera, the large scattering angle range from 0.5° - 25° and its pre-aligned and compact design. It is possible to move the laser to various positions along the radial direction of the optical transparent measurement geometries. Rotatable polarizers in the primary beam and the scattered light allow the measurement under all four polarization conditions which are possible in SALS under flow. Another advantage is the

possibility to combine the Rheo-SALS device with temperature control systems, which offer an accurate and uniform temperature distribution throughout the sample without any significant temperature gradients. Different temperature control systems based on Peltier or electrical heating over a measurement range from -40°C up to +300°C are available. In Figure 1 the Rheo-SALS setup in combination with a Peltier temperature control system is depicted.

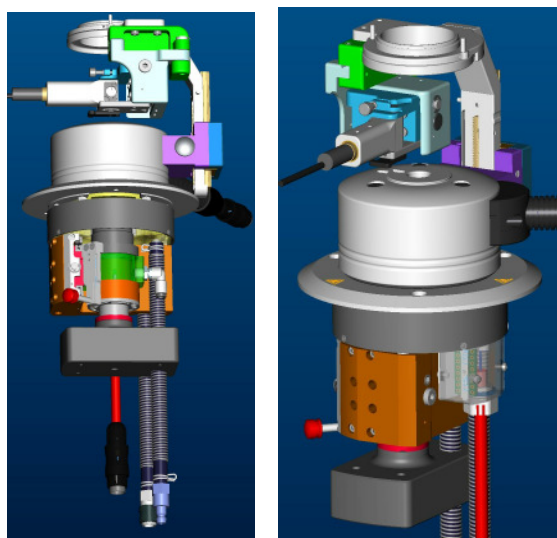

Figure 1. Schematic of the Rheo-SALS setup in combination with a Peltier temperature system.

For evaluating the Rheo-SALS setup different samples such as polymer blends, surfactant solutions and liquid crystals have been investigated. For all samples structural changes can be associated to a change in the rheological behavior proving the benefit of such a combined rheo-optical technique.

RHEO-SANS

In contrast to Rheo-SALS, SANS-experiments can not be performed in a normal laboratory. A neutron source, i.e. a reactor or a spallation source, and a SANS beamline are required. The Rheo-SANS setup is an accessory to the standard

rheometer. The Rheometer together with the SANS accessory is put into the SANS beamline. The SANS setup as depicted in Figure 2 is based on a convection principle for temperature control in the range from -100°C up to 200°C.



Figure 2. Rheometer with SANS device

Various geometries like concentric cylinder, parallel plate or an extensional fixture (SER) are possible. In the case of the concentric cylinder a tangential or a radial positioning of the neutron beam allows the detection of the scattering in different planes with respect to the shear direction. The concentric cylinder geometries are made of either quartz glass or titanium. Special care has been taken on the alignment of the system and to a solvent trap in order to prevent evaporation effects. Results on different samples are discussed.

RHEO-SAXS

The previously described SANS setup can be used for Rheo-SAXS applications as well. The only difference is that the material of the geometries is changed to polycarbonate. The thickness of the material at the positions where the x-rays pass is minimized in order to reduce absorption at the geometries.

CONCLUSIONS

Various techniques of Rheo-Small-Angle-Scattering (Rheo-SAS) such as Rheo-SALS, Rheo-SANS, and Rheo-SAXS are described. SAS is a very powerful method to be combined with rheology. Rheo-SAS devices on a standard rheometer allow a simultaneous determination of rheological properties by the rheometer and structural information by the SAS setups. For each system a variety of different geometries and large temperature ranges are available in order to facilitate Rheo-SAS experiments on a broad range of different sample and measurement conditions.