

## Rheology in Soil Mechanics - Structural Changes in Soils Depending on Salt- and Water Content

Wibke Markgraf, Rainer Horn

Institute for Plant Nutrition and Soil Science, Christian-Albrechts-University of Kiel,  
24118 Kiel, Germany.

### ABSTRACT

The application of rheometry in soil mechanical investigations is yet relatively uncommon.

A parallel-plate-rheometer MCR 300 was used for conducted oscillatory tests on Na-bentonite suspensions, saturated with NaCl and/ or aqua dest.. Rheometry may bridge the structure formation process between initial and on microscale to macroscale effects.

### INTRODUCTION

Rheology is regarded as the science of flow behaviour, where, based on isothermic equations, the deformation of fluids and plastic bodies subjected to external stresses may be described. Hooke's law of elasticity, Newton's law for ideal fluids (viscosity), Mohr-Coulomb's equation, and finally, Bingham's yielding are well known relationships and parameters in the field of rheology.

Rheometry is a well established measurement technique to determine the specific rheological properties of fluid and plastic bodies. However, the application of this technique in soil mechanical investigations, where triaxial, direct shear or oedometer tests are usually applied to derive soil stability parameters, rheometry is yet relatively uncommon. It has even been more conventional in chemical industry e.g. food science, polymer research.

This paper aims to introduce rheometry as a suitable method to determine the mechanical behaviour of soils and mineral suspensions when subjected to external stresses. To do this a Na-bentonite (IBECO SEAL-80) has been used as testing material. Suspensions of IBECO SEAL-80, as a model-substrate, and NaCl in different concentrations were produced and measured.

We used a parallel-plate-rheometer MCR 300 (Modular Compact Rheometer, Paar Physica, Ostfildern, Germany) to conduct oscillatory tests. From the stress-strain relationship parameters like thixotropy, storage and loss modulus, viscosity, yield stress and the linear viscoelastic deformation range were determined and calculated, respectively. Preliminary results of oscillatory tests (amplitude sweep and frequency sweep tests) show that rheometry is a potential method of investigating (micro)structural characteristics (single particles) of soils and mineral suspensions. Based upon three different salt concentrations and constant water content, structural stability (thixotropy), yield stress, including changes in viscosity (loss and storage moduli) are affected. Thus, rheometry may bridge the structure formation process between initial and on microscale to macroscale effects.

In forthcoming investigations concepts of osmotic potential and effective stress will be connected with rheometric methods. In

this way structural changes in dependency of different salt concentrations (i.e. different osmotic potentials) and water contents will be elaborated.

### RHEOLOGICAL AND RAW DATA

Some raw data needs to be mentioned (eqns. [1.1] to [1.5]), as those influence the basic conditions of tests.

$$\frac{\circ}{rad} = \frac{2\pi}{360} \quad [1.1]$$

$$\tau = \frac{1}{1000} \cdot \frac{3M}{2\pi R^3} \quad [1.2]$$

$$\dot{\gamma} = 6 \cdot \frac{n}{\alpha} \quad [1.3]$$

$$\gamma = \frac{18}{\pi} \cdot \frac{\varphi}{\alpha} \quad [1.4]$$

$$\omega = \frac{2\pi}{60} \cdot n \quad [1.5]$$

$\tau$  = shear stress [Pa]

$\gamma$  = shear deformation [%]

$\dot{\gamma}$  = shear rate [1/s]

$\omega$  = angular velocity [1/s]

where

$\tau$  [Pa] = F [N]/ A [m<sup>2</sup>], and

$\gamma$  [%] = s [m]/ h [m].

M = torque [mNm]

$\varphi$  = deflection angle [mrad]

n = speed [1/min]

R = radius [m]

$\alpha$  = cone angle [°]

The plate geometry of the rheometer MCR 300 (Figure 1) with plate-plate measuring system (PP MS) is determined by the plate radius R, according to DIN 53018. The distance H (or d) between the plates has to be  $H < R$ . The plate diameter is 25 mm, with an even surface, the plate distance 1 mm. A constant temperature of 20°C is generated by Peltier unit (Figure 2).



Figure 1: Rheometer MCR 300

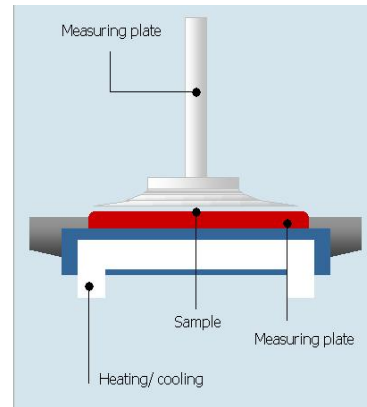

Figure 2: PP MS with Peltier unit

### MATERIAL

Major constituents of Na-bentonite clays as IBECO SEAL-80 are the minerals montmorillonite<sup>1</sup> and beidellite<sup>2</sup>, which both belong to the mineral group of smectites. Montmorillonite is developed by weathering of mica minerals and as new formations from other weathering products, in particular from volcanic tuffs and ashes. Due to its physical characteristics, montmorillonite is an unusual mineral. Montmorillonite belongs to the group of dioctahedral 2:1-layersilicates. The most conspicuous features of this material are the nearly unrestricted exchangeability of its

<sup>1</sup> Montmorillonite:  $Al_2 [(OH)_2 | Si_4O_{10}] \cdot nH_2O$

<sup>2</sup> Beidellite:  $(Na, Ca_{0.5})_{0.3} Al_2 (Si, Al)_4 O_{10}(OH)_2 \cdot 4H_2O$

intermediate layer cations and its excellent swelling capacity in aqueous solutions. The expansion of the interlayers can lead, in extreme cases, to the disintegration of the crystal network. These characteristics make montmorillonite a mineral with broad technical application possibilities.

The term Bentonite was formerly used for a plastic clay, that was found in upper cretaceous tuff in Fort Benton, Wyoming. IBECO SEAL-80, a Na-bentonite, can be assigned to the group of activated bentonites. These are bentonites with smectites whose initial composition of alkaline-earth-cations has been replaced with Na<sup>+</sup>-ions in a technical process named alkali-activation. In natural Na-bentonites (e.g. Wyoming, Greek or Southern German Bentonites) smectites are predominantly occupied with Na<sup>2+</sup>-ions in the intermediate layers. In Na-bentonites, Ca<sup>2+</sup> or Mg<sup>2+</sup>-ions also occur frequently and in varying concentrations.

Commonly, IBECO SEAL-80 is applied in construction and civil engineering e.g. as landfill sealing, for Caisson constructions as well as for Geosynthetic Clay Liners (GCL, bentonite mats) and for use in deep-mining.

Table 1. Characteristics of salt solutions (NaCl in aqua dest.), based on  $\Psi_0$  [kPa] = -36 · EC [dS/m], according to U.S.S.L. (1954)

Quality classes		C0	C1	C3
Salt content	[mg/l]	0	80	960
Salt concentration	[mol/l]	0	0.001	0.016
EC at 25°C	[µS/cm]	-	121.7	1296
$\Psi_0$	[kPa]	-	- 4.38	- 46.66

The electrical conductivity (EC) equals a comparable salt content [g/l].

250g (250 ml) NaCl + Aqua dest. Have been added to 50g Ibeco Seal-80 (0.2 kg/kg) and stirred manually (10 min.), afterwards mechanically with a Drigalskispatula. An average bulk density of 1.12 g/cm<sup>3</sup> has been calculated.

## METHOD

The Principle of oscillatory tests is depicted in Figure 3. Basically, an idealised illustration of shear strain is given. Due to an applied force F on a defined amount of substance - here represented by a block - deformation is caused by moving a rectangular or round pivotable plate over a face A (stable).

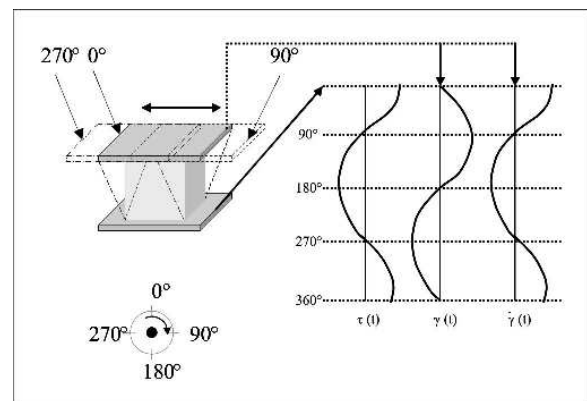

Figure 3. Principle of oscillatory tests within the LVE deformation range according to Maxwell (Mezger 2002).

In this context, to give a full description of parameters, a definition of complex viscosity  $\eta^*$ , as the ratio of the shear stress to the shear rate, alternatively to the complex shear modulus (BARNES et al. 1989) shall be outlined here (eqns. [2.1] and [2.2]). In oscillatory tests  $\eta^*$  represents the flow resistance of the sample (MEZGER 2002).

$$\tau(t) = \eta^* \cdot \dot{\gamma}(t) \quad [2.1]$$

$$\text{where } \eta^* = \eta' - i\eta'' \text{ and } G' = \eta' \cdot \omega$$

$$\eta^* = \tau(t) / \dot{\gamma}(t) = \text{const.} \quad [2.2]$$

in the linear viscoelastic range.

In the case of ideal viscous substances, a delay of the  $\tau(t)$  curve in relation to the  $\gamma(t)$  curve occurs with a phase shift angle of  $\delta = 90^\circ$ . As a basic condition, a complete contact between test sample and plates is essential.

All kinds of viscoelastic substances, respectively pastes, gels and soil pastes can be measured.

The storage modulus  $G'$  [Pa], as mentioned in equ. [2.1] represents the elastic behaviour of a sample, the loss modulus  $G''$  in [Pa] the viscous component. An idealised illustration is given in Figure 4.

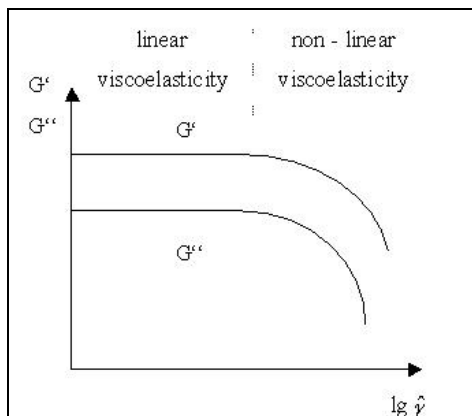

Figure 4. Graphs of  $G'$  and  $G''$  represent the relation of stored to lost elastic behaviour, depending on the shear rate, here, or on the angular frequency, where the linear viscoelastic (LVE) deformation range is defined (dotted line) (according to Mezger 2002).

If  $G' > G''$ : The elastic component prevails the viscose one, while if  $G' < G''$ : a sol-character is given, the viscous component exceeds the elastic; these substances are creeping or running (MEZGER 2002).

The yield stress can be calculated by using values from  $G'$ , the real part of stored elasticity, in opposite to  $G''$ , as imaginary part of lost elasticity and representing viscosity.

The relation of  $G''$  to  $G'$  equals  $\tan \delta$  as given in equation [3]:

$$\tan \delta = G''/G' \quad \text{where } G = \tau \cdot \eta \quad [3]$$

In oscillatory shear the complex shear modulus  $G^*$  is defined through the equation

$$\sigma = G^* \cdot \gamma \quad \text{where } G^* = G' + iG'' \quad [4]$$

according to the Maxwell model (BARNES et al. 1989), which is a combination of a dashpot (plasticity element) and a spring (elasticity element) in a row. This model can be used to illustrate effects of shear stress or strain on viscoelastic materials occurring in nature.

An amplitude sweep test, as an oscillatory test is characterised by a variable amplitude and constant frequency. The term 'sweep' stands for a function with a variable parameter. Either the shear stress (CSS) or the shear deformation (CSD) are controlled. Amplitude sweep tests are conducted to achieve informations about the flow behaviour of a substrate and especially its elastic part (stored elasticity), the LVE deformation range, marked as area between the points of the parallel running curves of  $G'$  and  $G''$  and their transition. The inflexion (transient) point equals the yield point.

In contrast to amplitude sweep tests a frequency sweep test is built up on a variable frequency and a constant amplitude, usually conducted with controlled shear deformation (CSD). As pre-condition the yield stress has to be determined first to assure that measurements are carried out within the LVE range. Curves of the storage modulus  $G'$ , the loss modulus  $G''$  and the complex viscosity  $|\eta^*|$  are displayed as a function of the angular frequency  $\omega$ . Alternatively, the complex viscosity  $|\eta^*|$  can be replaced by  $\tan \delta$ . Both give informations about the viscous behaviour, respectively the portion of viscosity in relation to elasticity. Frequency sweep tests appropriate to investigation regarding to short-term as well as to long-term behaviour. Thus, cyclic

adaptations of frequencies might be applied, e.g. frequency changes of farm implements (GARCIANO et al. 2001).

The so called LVE range (linear viscoelastic) - analysis is used for determining yield stress' – deriving from amplitude sweep tests, which have either deformation  $\gamma$  (controlled shear deformation, CSD) or shear stress  $\tau$  (controlled shear stress, CSS) as default. In the case of frequency sweep tests, calculations are based upon a Carreau equation (Carreau-Yasuda) and are generated automatically during tests.

## RESULTS

In Figure 5 the results from amplitude sweep tests with controlled shear deformation (CSD) with IBECO SEAL-80 (C0 and C1) are shown. The graphs of  $G'$ , the storage modulus and  $G''$ , the loss modulus are displayed, as well as calculated yield stresses (linear viscoelasticity (LVE) range calculations), which are given out as single points. Deformations averages between 2 to 2.5 %, at the corresponding yield point. The curves of  $G'$  are running parallel: C1 on the higher level than C0. The inflexion point of  $G'$  equals the yield point. In comparison to  $G''$ , the first inflexion of those graphs – representing the imaginary part of lost elasticity – are analogous to the yield points of  $G'$ . At this point the substance starts to creep, the loss of elasticity reaches a maximum. The state of plasticity is obtained.

A result of a frequency sweep test is depicted in Figure 6.

With special regard to C3, the highest NaCl-concentration in solution, the level of  $G''$  is  $C3 \ll C1$  and  $C0$ , the distance of  $G'$  to  $G''$  is the largest. Calculating  $\tan \delta$ , the ratio of  $G''$  to  $G'$  is 0.06 in all cases, a typical ratio for gels or dispersions. Here, the levels of  $G'$  and  $G''$  are the decisive factors.

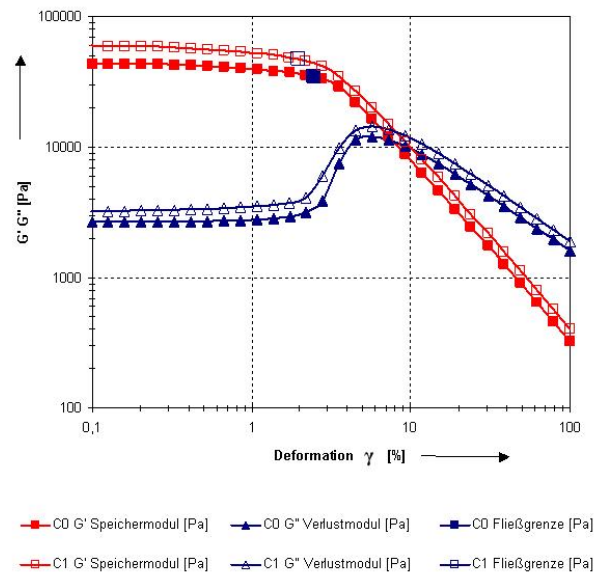

Figure 5. Results from an amplitude sweep test with controlled shear deformation (CSD)

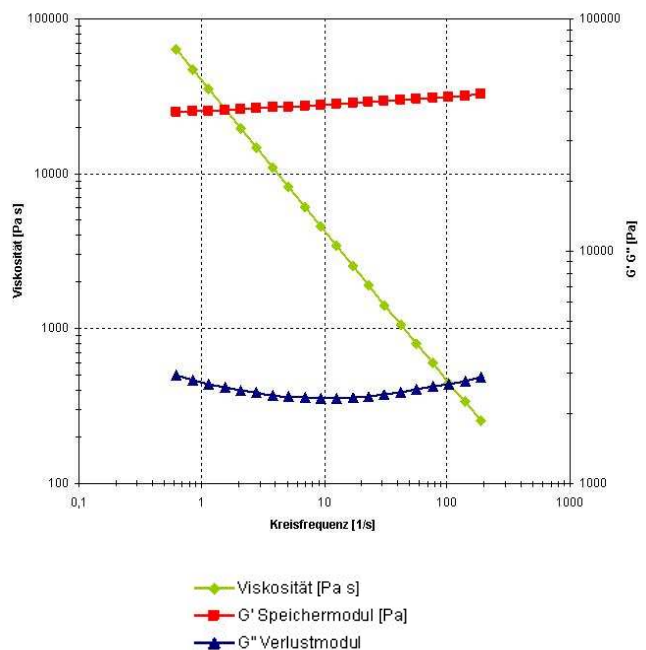

Figure 6. Result from a frequency sweep test, Ibeco Seal 80, C3, deformation const. = 0.1 %

## OUTLOOK

Preliminary results showed that rheometry is a potential method in soil mechanics to investigate changes in microstructure induced by certain salt concentrations, a defined water content,

different clay types as well as frequency ranges and stress magnitude. In forthcoming investigations, concepts of water potential and effective stress will be connected with rheological methods and effects on the film continuity in micro- and mesopores depending on the chemical aspect of salts. Therein, considering research aspects of GHEZZEHEI and OR (2001), TULLER and OR (2002, 2003), lies the main focus of upcoming investigations beside an illustration of practicability of rheological methods for both soil mechanics in theory and agriculture, including aspects of vibration effects of farm implements (e.g. GARCIANO et al. 2001).

#### REFERENCES

1. Barnes, H.A., Hutton, J.F., and Walters, K. (1989), "An Introduction to Rheology". *Rheol. Ser.* **3**. Elsevier, Oxford, New York, Tokyo.
2. Garciano L., Torisu, R., Takeda, J., and Yoshida, J. (2001), "Resonance Identification and Mode Shape Analysis of Tractor Vibrations", *J. JSAM* **63**: 45-50.
3. Ghezzehei, T.A. and Or, D. (2001), "Rheological Properties of Wet Soils and Clays under Steady and Oscillatory Stresses", *Soils Sci. Soc. Am. J.* **65**: 624-637.
4. Mezger, T.G., 2002. *The Rheology-Handbook – for Users of Rotational and Oscillatory Rheometers*. Vincentz-Verlag. Hannover.
5. U.S.S.L., Staff of, (1954), "Diagnosis and Improvement of Saline and Alkaline Soils", USDA Handbook no. 60. GPO: Washington, D. C.